

The Digital Evolution of Backflow Testing is Here.

Introducing the Mako MK5
A field-rugged, water-resistant digital solution engineered for precision and efficiency.

- Built on over 25 years of experience in developing rugged field instrumentation.

- Goes beyond the limitations of mechanical gauges with unique digital features and Bluetooth connectivity.



Engineered for the Realities of Field Work.



Effortless Data Management

- The unique **Capture Value function** eliminates the need for pen and paper, allowing you to focus on the assembly, not the gauge.
- **Bluetooth connectivity** provides the missing link between field testing and your app-based software.



Unmatched Readability

- A **large, backlit digital display** ensures clear readings in any lighting condition, from bright sunlight to dark meter pits.



Superior Ergonomics & Durability

- A comfortable, secure grip, even when wet, thanks to its ergonomic design and soft rubber over-moulding.
- Designed to sit flat or hang securely from its strong hook, providing hands-free operational flexibility.

A Tour of the Mako MK5: The Front Interface.

The MK5's controls are intuitively organised for efficient operation. Let's break down each section.

Bleed Controls

For internal flushing and purging.
(Labels 2 & 4)

Main Digital Interface

For power, data capture, and navigation.
(Labels 5, 6, 7)

Main Pressure Passthrough

For primary pressure connections and control.
(Labels 9, 11, 13)

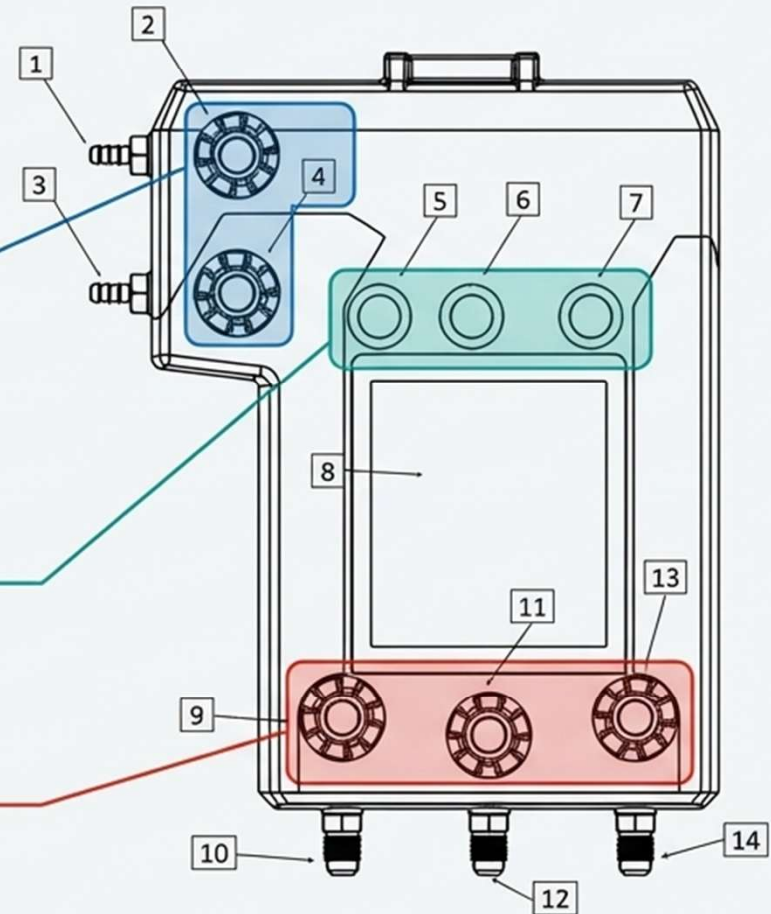

Mastering Your Controls: Bleed Valves & Main Buttons.

Bleed System

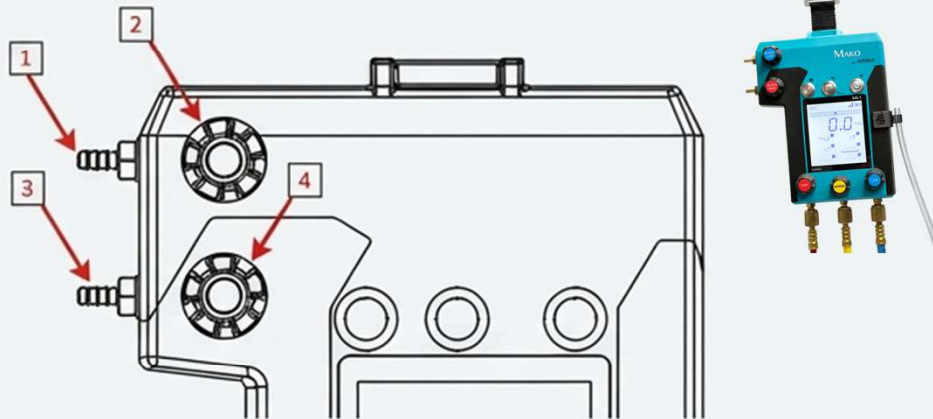

- **Low Bleed Port (1) & Knob (2):** Connects the Low Bleed Port hose. Turn knob counterclockwise to open.
- **High Bleed Port (3) & Knob (4):** Connects the High Bleed Port hose. Turn knob counterclockwise to open.

Key Benefit: The 5-valve design allows for internal flushing through these bleed valves, eliminating the need to flush through a separate bypass port.

Digital Interface

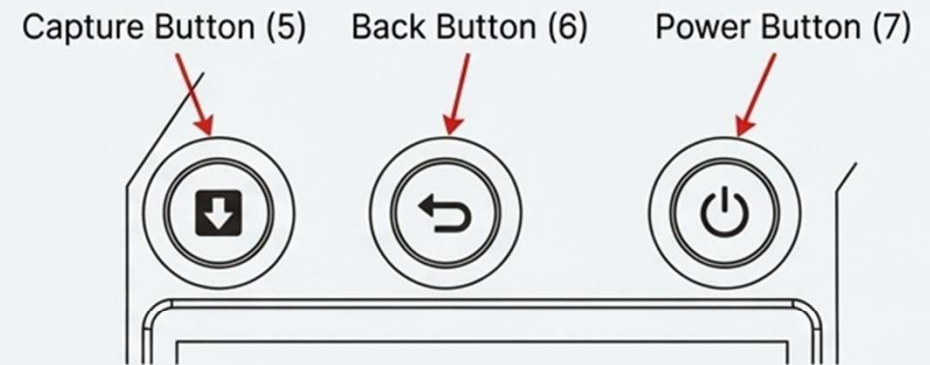

- **Capture Button (5):** A single press captures the current reading to one of six memory positions.
- **Back Button (6):** Press to delete the previous captured value. Press and hold for 1.5 seconds to clear all captured values.
- **Power Button (7):** Hold to turn the unit on or off. A quick press toggles the backlight.

Important Note: Do not exceed finger tight when closing the knobs. Do not use any external tools to increase torque.

Mastering Your Controls: Pressure Ports & Passthrough Knobs.

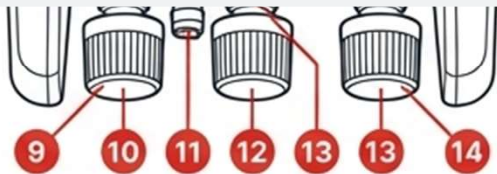

High Pressure Passthrough

- **Knob (9) & Port (10):** Connect the higher pressure source here. Turn knob counterclockwise to open.

Bypass Port (Vent Port)

- **Knob (11) & Port (12):** Used for transferring water, particularly when testing Reduced Pressure Backflow Assemblies (RPBAs).

Low Pressure Passthrough

- **Knob (13) & Port (14):** Connect the lower pressure source here.

Differential Pressure Principle

The Mako displays High Pressure minus Low Pressure. When testing a backflow assembly or across any pressure drop, connect the higher pressure source to the High port and the lower pressure source to the Low port.



Important Note: Do not exceed finger tight when closing the knobs. Do not use any external tools to increase torque.

Designed for the Field: A Look at the Rear.

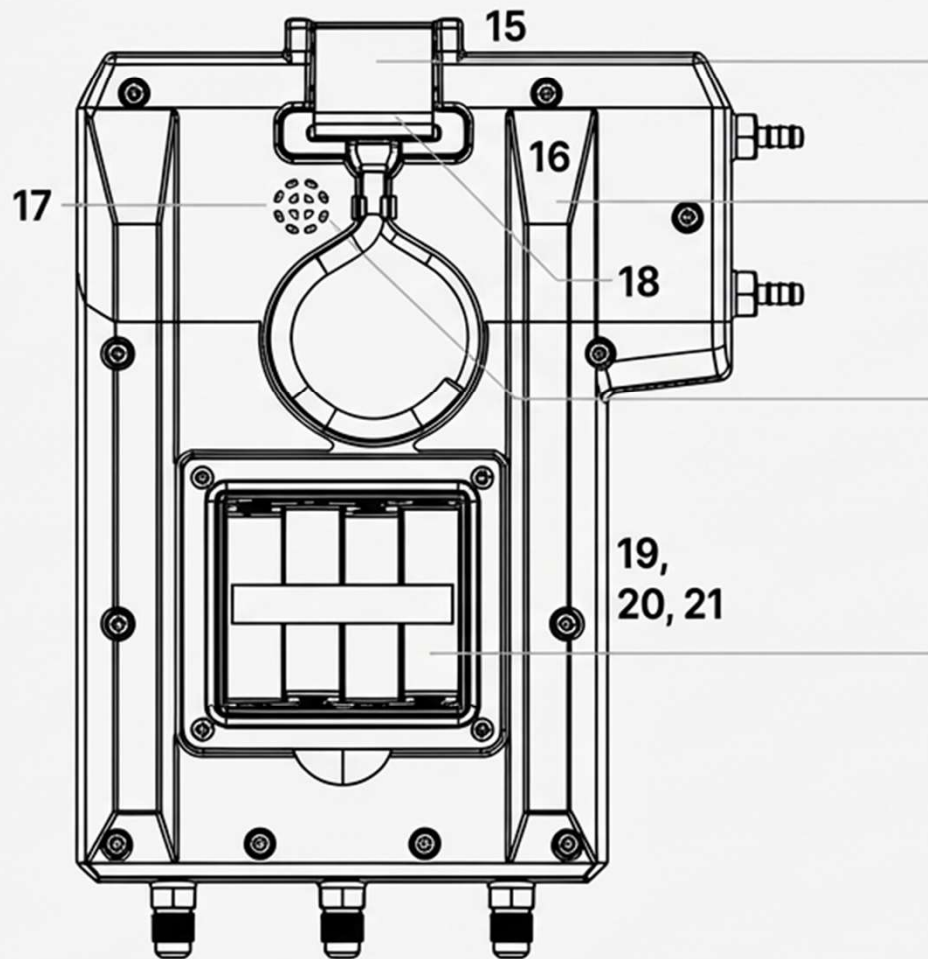

- **15. Hook with Strap:** For hanging the Mako during tests. Only hang on well-fixed pipes.
- **16 & 18. Hook Clip & Groove:** Keeps the hook safely stowed when not in use. The hook's orientation can be reversed.
- **17. Moisture Vent:** Allows condensate to escape while preventing water ingress.
- **19, 20, 21. Battery Compartment:** Houses 4x AA batteries (rechargeable or alkaline). The cover lip and gasket are crucial for maintaining water resistance. Ensure all four screws are tightened to keep the gasket compressed.

The Digital Display: All Your Data at a Glance.

A. Rate of Change Graph:
Shows measurement stability.

B. Main Display: Live reading from the differential pressure sensor.

C. Captured Values: Stores up to six readings.

D. Active Position Cursor:
Shows where the next value will be saved.

E. Auto Power Off (APO) Indicator: On by default (30 mins).

F. Calibration (CAL) Mode Indicator.

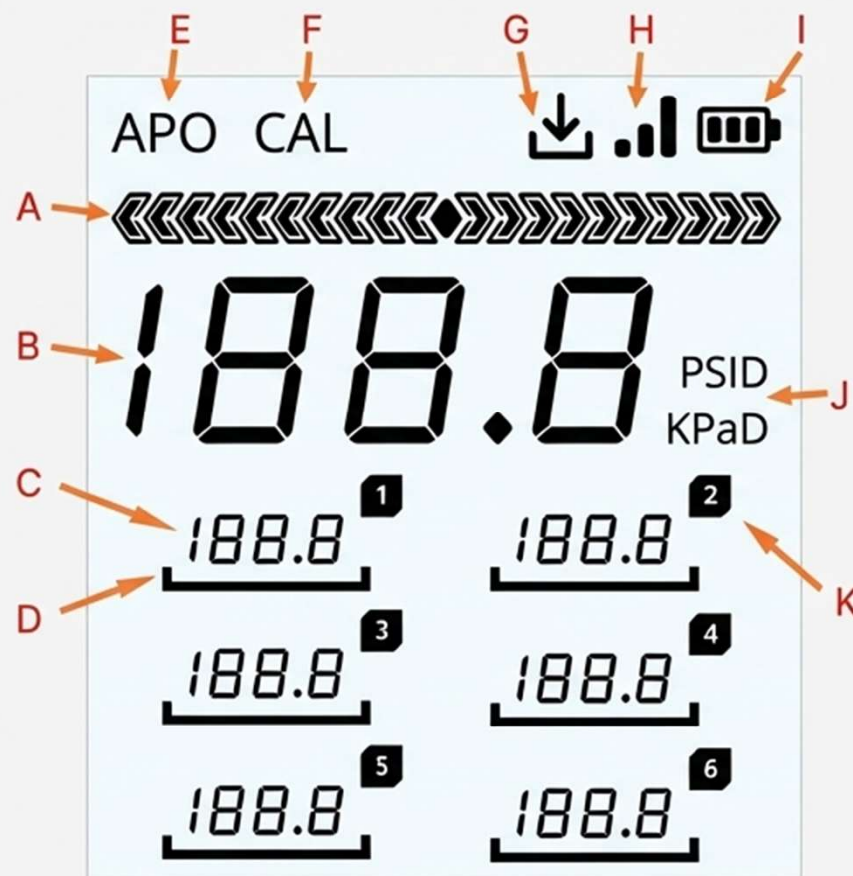

G. Download Indicator:
For firmware updates.

H. Wireless Connection Indicator: Shows Bluetooth status.

I. Battery Life Indicator:
Blinks when low.

J. Units: PSID or KPaD.

K. Captured Position ID:
Labels for values 1-6.

Interpreting the Rate of Change Graph.

The graph provides instant feedback on pressure stability, helping you decide the optimal moment to capture a reading. It indicates how quickly the live reading is changing and also helps level the sensor correctly.

Stable Pressure



The graph shows a single dot in the middle, or one to two units filled. This is the ideal time to capture a reading for best results.

Increasing Pressure



Arrows on the right side of the graph will darken. The faster the increase, the more arrows will be shown.

Decreasing Pressure



Arrows on the left side of the graph will darken. The faster the decrease, the more arrows will be shown.

Paperless Data with the Capture Function.

The Advantage

Capturing values eliminates the need for a pencil and paper at each assembly. It allows the tester to focus on the backflow assembly itself, which is crucial for accurately recording relief valve or air inlet valve opening points.

How it Works

- The **Active Position Cursor** (underline) shows where the next reading will be stored (Positions 1-6).
- **To Capture a Value:** Press the **Capture Button**. The live reading from the Main Display will be stored in the active slot.
- **To Clear a Single Value:** Press and release the **Back Button** to delete the most recently captured value.
- **To Clear All Values:** Press and hold the **Back Button** until all values are cleared.

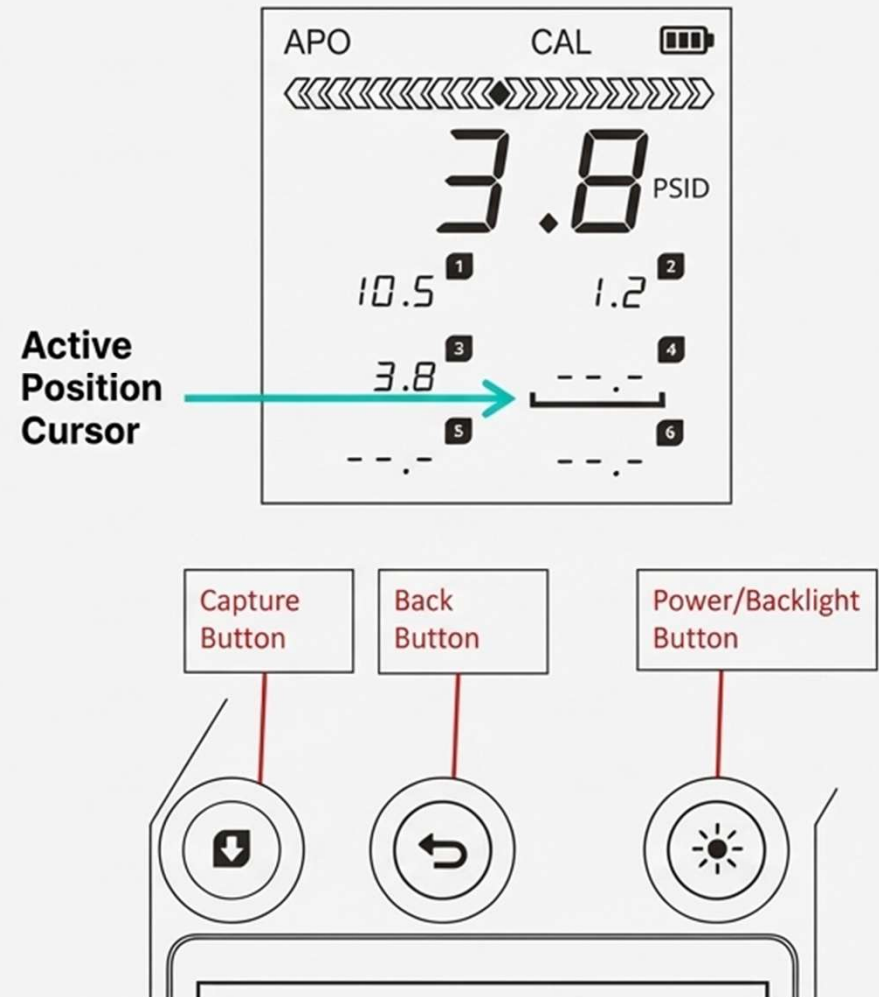

Customising Your MK5: Secondary Operations.



Toggleing the Backlight

- To preserve battery life, the backlight defaults to OFF on power-up.
- To toggle the backlight ON or OFF, briefly press and release the **Power/Backlight button**. Be careful not to hold it too long, as this will power the unit off.



Auto Power Off (APO)

- The Mako automatically turns off after 30 minutes of non-use.
- To disable this feature, hold the **Back button** while powering on the unit. The 'APO' indicator will no longer be visible on the display.



Changing Units

- The Mako defaults to PSID.
- To change units between PSID and KPaD, hold the **Capture button** while powering on the unit.

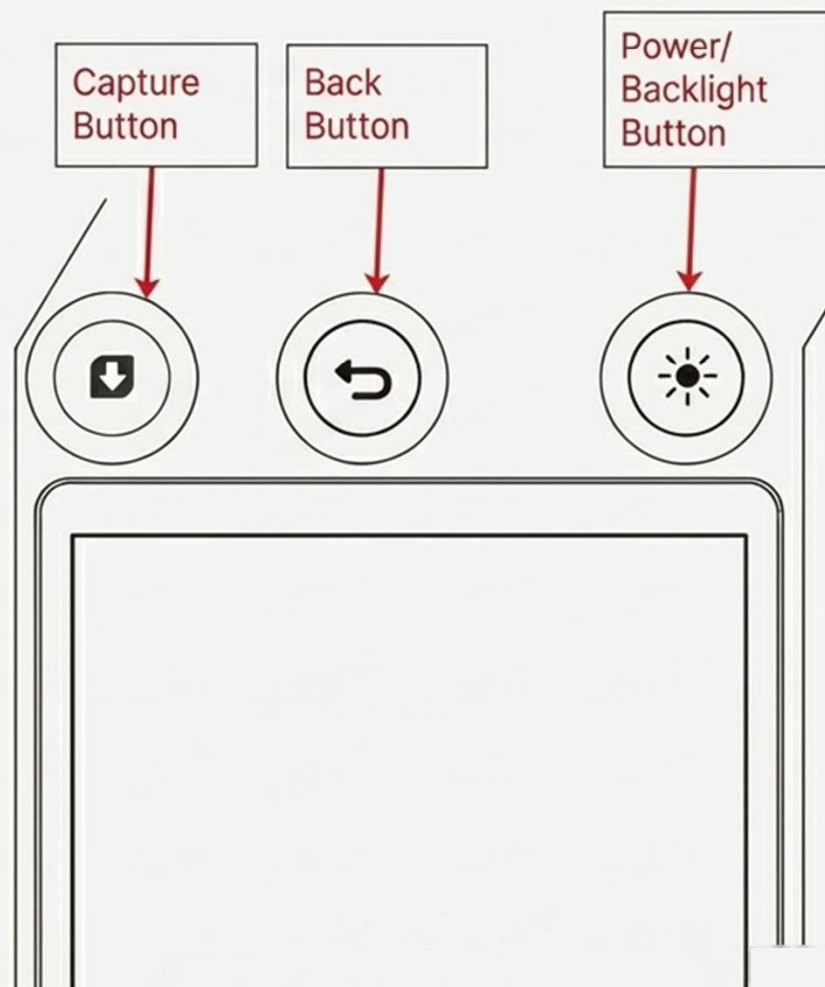

Technical Specifications: Performance & Durability.

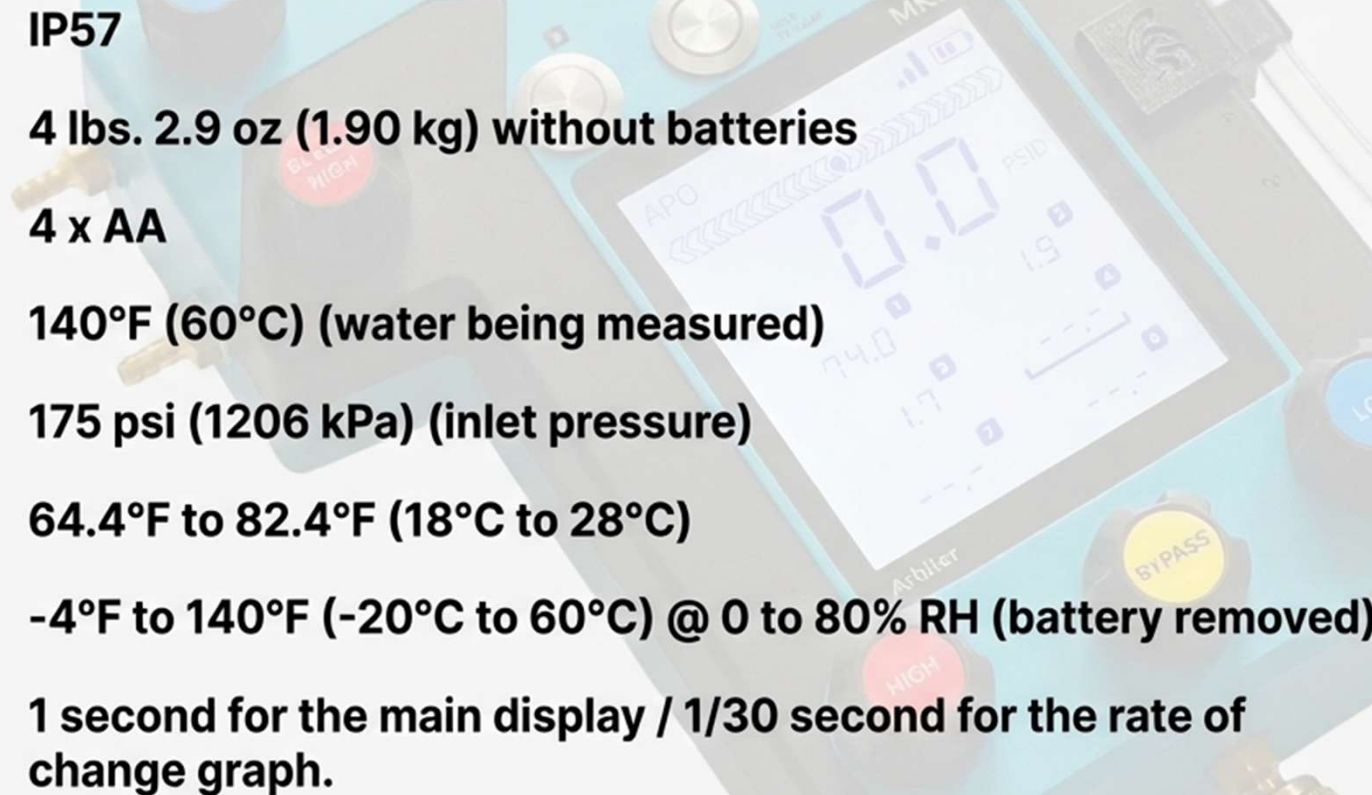
A handheld electronic device, the MAKO Arbiter MK5, is shown in the background. It has a light blue top and a black bottom. The top features a 'BLEED LOW' knob, a 'BLEED HIGH' knob, and a 'BYPASS' knob. The front has a large color LCD screen displaying various data points and graphs. The screen shows 'APO', '74.0', '1.7', '1.9', and 'PSID'. The device is labeled 'MAKO Arbiter MK5' and 'Arbiter'.

Certified Accuracy You Can Depend On.

✓ Suitability Criteria

In addition to being capable of measuring pressure differentials RPZ test equipment should be:

1. Capable of measuring pressure differential in kPa (or equivalent).
The minimum unit of measurement (increments for all gauges) should be at least 1 kPa (or equivalent) unless testing a RPZ valve incorporating a number 2 check valve which conforms to BS EN 13959, in which case the minimum increment shall be at least 0.5 kPa (or equivalent). The test equipment must be capable of measuring differentials between at least 0 - 34 kPa (or equivalent).
2. Able to record all the required differential measurements.
3. Is designed to test the valve under its normal operating conditions. For example, if a hot water system it is suitable to use at the operating temperature.
4. Safe to use where the valve is located. For example, would the site operate have any safety concerns.
5. Capable of completing all parts of the compliance test.
6. Marked with a unique identifier such as a serial number.
7. Capable of being calibrated.



The 5-Valve Advantage: Faster, Smarter Testing.

- The Mako MK5's 5-valve design is a fundamental shift from traditional 3-valve gauges.
- **Benefit:** This allows for internal flushing and purging directly through the high and low side bleed valves.
- **Result:** You can complete each test without having to disconnect hoses to flush through a separate bypass port, saving valuable time and effort on every job.
- This streamlined process is made possible by the advanced internal flow design.

